

ON THE INITIAL HEATING OF A BOUNDED VOLUME
OF A CONTINUOUS MEDIUM

A. D. Myshkis and L. A. Temkin

UDC 536.24.02

We examine the asymptotic behavior of the solutions of the heat conduction equation in a problem concerning initial heating. We focus our main attention on the term in the expansion which determines the gradient of the temperature field.

If the flow of heat through the surface of a body in a direction from the outside toward the interior is positive, the body begins to warm up. The study of this initial heating is interesting from a theoretical point of view (it is the simplest example of a non-established process in a system with an infinite number of degrees of freedom); it also has numerous applications. We present here some simple general considerations in this regard; in addition, we present the results of the calculation of various methods for the initial heating of a spherical volume according to a linear law.* These results are applied to an approximate calculation of a thermo-capillary force acting on a small heterogeneous body placed in a liquid-filled container.

It is also of interest to consider other problems of mathematical physics, which lead to non-established processes, in particular, to parameters varying according to a linear law.

1. For simplicity we consider a homogeneous isotropic medium occupying a domain D , bounded by a closed piecewise-smooth surface S . (A major part of our discussion carries over directly to nonhomogeneous and nonisotropic media, and, mathematically, to a domain with an arbitrary boundary; it also carries over to a wide class of parabolic equations and systems whose extent it would be of interest to define more exactly). Let, c , γ , and $\kappa = \gamma/c$ be, respectively, the specific volumetric heat capacity, the coefficient of thermal conductivity, and the coefficient of thermal diffusivity; also let $u(x, t)$ ($x = (x_1, x_2, x_3)$) be the temperature field, and let $q(x, t)$ be the heat flow intensity applied throughout the volume, calculated per unit volume and unit time. Since the heat flow passing into D through S can be interpreted as a heat flow inserted into D in the immediate proximity of S , with D thermally insulated, then, with no loss of generality, we can formulate the initial heating problem as a problem concerning the solution of the equation

$$\frac{\partial u}{\partial t} = \kappa \Delta u + \frac{1}{c} q(x, t) \quad (0 \leq t < \infty, x \in \bar{D} = D \cup S) \quad (1)$$

subject to the boundary condition

$$\left. \frac{\partial u}{\partial n} \right|_S = 0 \quad (0 \leq t < \infty) \quad (2)$$

and an initial condition

$$u|_{t=0} = u_0(x) \quad (x \in \bar{D}). \quad (3)$$

*Linear, homogeneous, initial heating of a spherical volume and of an infinite circular cylinder through the surface were studied in [1, 2]. Nonlinear, homogeneous, initial heating of a spherical volume was studied in [3]. The following terminology is employed for linear initial heating: quasi-stationary behavior, regular behavior of the second kind, linear regular behavior.

Physicotechnical Institute of Low Temperatures, Academy of Sciences of the Ukrainian SSR, Khar'kov. Translated from *Inzhenerno-Fizicheskii Zhurnal*, Vol. 25, No. 3, pp. 518-529, September, 1973. Original article submitted June 27, 1972.

© 1975 Plenum Publishing Corporation, 227 West 17th Street, New York, N.Y. 10011. No part of this publication may be reproduced, stored in a retrieval system, or transmitted, in any form or by any means, electronic, mechanical, photocopying, microfilming, recording or otherwise, without written permission of the publisher. A copy of this article is available from the publisher for \$15.00.

Moreover, the given function $q(x, t)$ can be a generalized function of at most the first order with support on $\bar{D} \times [0, \infty]$, i. e., if the concern is with applied problems, then, along with heat sources distributed throughout the volume, we can have sources concentrated on surfaces, curves, and at individual points in D or on S . The initial function $u_0(x)$ can also be a generalized function, the solution being understood in the standard generalized sense. We remark, also, that D can have multiple boundary points; then in \bar{D} each multiple boundary point A is considered only as many times as its multiplicity according to the various methods of approach to A from D .

2. The study of the asymptotic behavior of the solution is based on an application of the Green's function $G(x, t; \xi)$ ($x, \xi \in \bar{D}$, $0 \leq t < \infty$), which serves as the solution of the problem (1)-(3) when $q = \delta(x - \xi)\delta(t)$, $u_0(x) \equiv 0$, or, equivalently, when $q \equiv 0, u_0(x) = (1/c)\delta(x - \xi)$. This function is symmetric ($G(x, t; \xi) = G(\xi, t; x)$), is continuous in the set of its arguments outside of the set $\{x = \xi, t = 0\}$, and has for $t \rightarrow \infty$ the asymptotic representation

$$G(x, t; \xi) = \frac{1}{c|D|} + G_1(x, t; \xi) = \frac{1}{c|D|} + O(\exp(-\lambda_1 t)), \quad (4)$$

where $|D| = \text{mes } D$, λ_1 is the smallest positive characteristic value of the second boundary value problem for the Laplace operator in D , and the estimate of the remainder term in equation (4), as it is also in the formulas to follow, is uniform with respect to x and ξ .

The solution of the initial problem (1)-(3) can be written with the aid of the Green's function in the form of a sum of integrals

$$u(x, t) = \int_0^t d\tau \int_D G(x, t - \tau; \xi) q(\xi, \tau) d\xi + c \int_D G(x, t; \xi) u_0(\xi) d\xi. \quad (5)$$

From this, by virtue of the relation (4), we can make a statement, first of all, concerning the influence of the initial function $u_0(x)$ on the asymptotic behavior of the solution as $t \rightarrow \infty$; it adds a constant term and a term of order not higher than $\exp(-\lambda_1 t)$. Therefore, in problems where these terms are not essential, the initial function can be changed arbitrarily, i. e., we can consider the problem as one without an initial condition.

3. Putting $u_0(x) \equiv 0$ for simplicity, we obtain from equation (5), by virtue of the relation (4), the result

$$u(x, t) = \frac{1}{c|D|} \int_0^t d\tau \int_D q(\xi, \tau) d\xi + \int_0^t d\tau \int_D G_1(x, t - \tau; \xi) q(\xi, \tau) d\xi = u_1(t) + u_2(x, t). \quad (6)$$

When $\int_D q dx \neq 0$, the first term is the principal term, but since it is a function of t only, i. e., it determines the initial heating of the portion of the medium in the body under consideration, it is of essential interest to study the second term, which determines the gradient of the temperature field. For this we carry out an integration by parts with respect to t , which yields

$$u_2(x, t) = \int_D G_2(x, 0; \xi) q(\xi, t) d\xi - \int_D G_2(x, t; \xi) q(\xi, 0) d\xi - \int_0^t d\tau \int_D G_2(x, t - \tau; \xi) q'_t(\xi, \tau) d\xi, \quad (7)$$

where

$$G_2(x, t; \xi) = \int_t^\infty G_1(x, \tau; \xi) d\tau = (O(\exp(-\lambda_1 t))).$$

If $q'_t(x, t)$ is infinitely small in comparison with $q(x, t)$ as $t \rightarrow \infty$, then the principal term on the right side of equation (7) is the first term $u_{21}(x, t)$, which has a comparatively simple structure; as $t \rightarrow \infty$ the order of the second term is $O(\exp - \lambda_1 t)$; to define more exactly the order of the third term, we can carry out a repeated integration by parts, which, incidentally, makes it possible to determine the asymptotic representation of the solution more precisely. Moreover, if q exhibits a power-law type behavior, we can then use the simple formula $\int_0^\infty \exp(-\lambda(t - \tau)) \tau^p d\tau \sim (1/\lambda) t^p (t \rightarrow \infty)$, valid for $\lambda > 0$ for real p of arbitrary sign.

4. It follows from Eq. (6) that if we replace $q(x, t)$ by $\tilde{q}(x, t)$, then $\int_0^\infty \int_D |\tilde{q}(x, t) - q(x, t)| dx dt < \infty$ becomes $\tilde{u}_1(t) - u_1(t) \xrightarrow{t \rightarrow \infty} \text{const}$ (\tilde{u} is formed for the solution with the altered flow). If $\max |\tilde{q}(x, t) - q(x, t)| \rightarrow 0$, then $\max_x |\tilde{u}_2(x, t) - u_2(x, t)| \rightarrow 0$. If $\int_D |\tilde{q}(x, t) - q(x, t)| dx \rightarrow 0$, then $\int_D |\tilde{u}_2(x, t) - u_2(x, t)| dx \rightarrow 0$.

5. The Green's function G admits the expansion

$$G(x, t; \xi) = \frac{1}{c|D|} + \frac{1}{c} \sum_j f_j(x) f_j(\xi) \exp(-\lambda_j t),$$

where the summation extends over all positive characteristic values λ_j of the second boundary value problem for the Laplace operator in D , and where $f_j(x)$ is understood to be a normalized characteristic function corresponding to λ_j . From this we have

$$G_2(x, t; \xi) = \frac{1}{c} \sum_j \frac{1}{\lambda_j} f_j(x) f_j(\xi) \exp(-\lambda_j t), \quad (8)$$

and we can therefore write the first term on the right side of equation (7) in the form

$$u_{21}(x, t) = \frac{1}{c} \sum_j \frac{1}{\lambda_j} \int_D q(\xi, t) f_j(\xi) d\xi \cdot f_j(x).$$

6. We consider the simplest case of linear initial heating in which the flow entering the medium is stationary, i. e., $q = q(x)$. In this case, from the relations (6) and (7) we obtain

$$u(x, t) = \frac{\bar{q}}{c} t + u_{21}(x) + O(\exp(-\lambda_1 t)),$$

where

$$\bar{q} = \frac{1}{|D|} \int_D q(x) dx, \quad u_{21}(x) = \int_D G_2(x, 0; \xi) q(\xi) d\xi. \quad (9)$$

It is readily verified that the sum of the first two terms, explicitly written out here, constitutes a particular solution of Eq. (1), satisfying the boundary condition (2); in addition, $u_{21}(x)$ must satisfy the Poisson equation

$$\Delta u = \frac{1}{\gamma} [\bar{q} - q(x)] \quad (x \in \bar{D}) \quad (10)$$

and the boundary condition (2). Since the mean value of the right side is equal to zero, the necessary condition for solvability is satisfied; moreover, the solution of Eq. (10) is determined to within an arbitrary constant term; for the given initial condition (3) this term can be determined from the relation

$$\int_D u_{21}(x) dx = \int_D u_0(x) dx.$$

We note that the desired solution of Eq. (10) is given by the last expression in Eqs. (9), which can be rewritten in the form

$$u_{21}(x) = \int_D [-\gamma G_2(x, 0; \xi)] \frac{1}{\gamma} [\bar{q} - q(\xi)] d\xi;$$

therefore, the function $\gamma G_2(x, 0; \xi)$ represents the Green's function for the Poisson equation with the boundary condition (2) (by the Green's function we understand here the kernel in the integral representation of the solution of the problem in terms of its nonhomogeneous term). This enables us to form, in a number of cases, the dominant first term in the representation (7), thereby by-passing construction of the Green's function $G(x, t; \xi)$ for the Eq. (1).

It should be noted that the Green's function $H(x; \xi)$ for Poisson's equation with the boundary condition (2) and the symmetry condition $H(x; \xi) \equiv H(\xi; x)$ is determined only to within the term $g(x) + g(\xi)$, where g is an arbitrary function. This arbitrariness is connected with the fact that the study is carried out "on the spectrum of the problem." This, in fact, defines the basic specific mathematical nature of the problem.

If some Green's function $H(x; \xi)$ is known for all $x, \xi \in D$, we can then put

$$G_2(x, 0; \xi) = -\frac{1}{\gamma} H(x; \xi) + g(x) + g(\xi)$$

and determine the function g from the condition of orthogonality to a constant (see Eq. (8)):

$$0 = \int_D G_2(x, 0; \xi) d\xi = -\frac{1}{\gamma} \int_D H(x; \xi) d\xi + g(x)|D| + \int_D g(\xi) d\xi,$$

whence

$$g(x) = -\bar{g} + \frac{1}{\gamma|D|} \int_D H(x; \xi) d\xi.$$

Taking averages, we obtain

$$\bar{g} = -\bar{g} + \frac{1}{\gamma} \bar{H}, \text{ whence } \bar{g} = \frac{1}{2\gamma} \bar{H},$$

$$g(x) = -\frac{1}{2\gamma} \bar{H} + \frac{1}{\gamma|D|} \int_D H(x; \xi) d\xi$$

and, finally,

$$G_2(x, 0; \xi) = -\frac{1}{\gamma} H(x; \xi) - \frac{1}{\gamma} \bar{H} + \frac{1}{\gamma|D|} \int_D H(x; \xi) d\xi + \frac{1}{\gamma|D|} \int_D H(x; \xi) dx.$$

7. Let $H(x; \xi)$ be known only for $\xi \in S$, i. e., suppose that we know the Green's function for the second boundary value problem for Laplace's equation, and let the support of $q(x)$ belong entirely to S , i. e., we are talking here of initial heating of the domain D through its surface. In this case, just as in the conditions of the last paragraph of §6, we can construct the function $u_{21}(x)$ directly, by-passing the construction of the function $G_2(x, 0; \xi)$. To do this, it is necessary to make, using the Eq. (10), the substitution

$$u_{21}(x) = v(x) + \frac{\bar{q}}{6\gamma} |x|^2, \quad (11)$$

as a result of which we obtain for v in D Laplace's equation and the boundary condition

$$\left. \frac{\partial v}{\partial n} \right|_S = -\frac{1}{\gamma} b(x) - \frac{\bar{q}}{3\gamma} |x| \cos(x, n), \quad (12)$$

where n is the inner normal and $b(x)$ is the intensity of the heat flow entering through S per unit area per unit time; in addition, $\bar{q} = 1/|D| \int_S b(x) dx = (|S|/|D|) \bar{b}$, where $|S|$ is the area of the surface S . From Eq. (12) we obtain, with the aid of the Green's function, an expression for $v(x)$; from it and from Eq. (11) we then find

$$u_{21}(x) = \frac{\bar{q}}{6\gamma} |x|^2 - \frac{1}{\gamma} \int_S H(x, \xi) \left[b(\xi) + \frac{\bar{q}}{3} |\xi| \cos(\xi, n) \right] d\xi + \text{const.} \quad (13)$$

If the Green's function for the domain D is not known, the function $v(x)$ can then be constructed numerically, for example, by solving the integral equation on S for the density of the potential of a simple layer. We can also make use of an analogous equation obtained from the known integral representation of the harmonic function $v(x)$ in terms of the values of $v|_S$ and $\partial v/\partial n|_S$ with the aid of an arbitrary fundamental solution of Laplace's equation. The situation simplifies somewhat if we choose the fundamental solution such that its normal derivative is constant on a part of S : the integral equation need then be solved only on the remaining part of S . In this way we can eliminate from S a flat or spherical portion, if such exists.

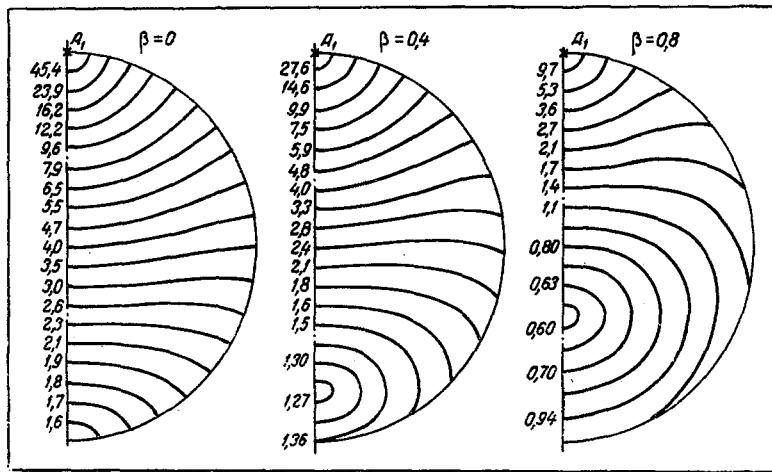

Fig. 1. Homogeneous influx of heat over the surface and a heat source at the point A_1 .

8. As one of the few cases in which the function $H(x, \xi)$ can be constructed in closed form, we cite the practically important case in which the domain D is a ball (see, for example, [4], p. 391). For $\xi \in S$ this function is given by

$$H(x; \xi) = -\frac{1}{4\pi} \left(\frac{2}{|x-\xi|} + \frac{1}{R} \ln \frac{2R}{R + |x-\xi| - |x| \cos(x, \xi)} \right) + \text{const.} \quad (14)$$

By virtue of Eq. (13) we obtain

$$u_{21}(x) = \frac{\bar{q}}{6\gamma} |x|^2 + \frac{1}{4\pi\gamma} \int_S \left[\frac{2}{|x-\xi|} + \frac{1}{R} \ln \frac{2R}{R + |x-\xi| - |x| \cos(x, \xi)} \right] \left[b(\xi) - \frac{\bar{q}}{3} R \right] d\xi + \text{const}$$

(henceforth we give the function $u_{21}(x)$ to within an arbitrary constant). This result can be simplified somewhat if we take into account the fact that the function (14) is harmonic in D with respect to x ; therefore the function

$$\int_S \left[\frac{2}{|x-\xi|} + \frac{1}{R} \ln \frac{2R}{R + |x-\xi| - |x| \cos(x, \xi)} \right] \left(-\frac{\bar{q}}{3} R \right) d\xi$$

is also harmonic in D . But since it depends only on $|x|$, it is then equal to a constant. (We can ascertain its value. For this we need to put $x = 0$, whence we find that the integral is equal to $(8/3)\pi R^2 \bar{q}$.) Thus

$$u_{21}(x) = \frac{\bar{q}}{6\gamma} |x|^2 + \frac{1}{4\pi\gamma} \int_S \left[\frac{2}{|x-\xi|} + \frac{1}{R} \ln \frac{2R}{R + |x-\xi| - |x| \cos(x, \xi)} \right] b(\xi) d\xi. \quad (15)$$

9. For certain special classes of flows $b(x)$ the expression (15) simplifies. This is the case, first of all, if the flow is concentrated at individual points. The integral (15) is then replaced by a sum. Another simple case is that of a homogeneous flow ($b(x) \equiv \text{const}$), as indicated at the end of §8; the integral in Eq. (15) then does not depend on x , i. e.,

$$u_{21}(x) = \frac{\bar{q}}{6\gamma} |x|^2 = \frac{\bar{b}}{2\gamma R} |x|^2. \quad (16)$$

Of special interest are axially symmetric flows for which, in the spherical coordinates φ and ϑ , the intensity depends only on the latitude ϑ , $b = b(\vartheta)$. Let us assume, at first, that the flow Q is uniformly distributed along the parallel $\vartheta = \vartheta_0$. Then, by virtue of the relation (15),

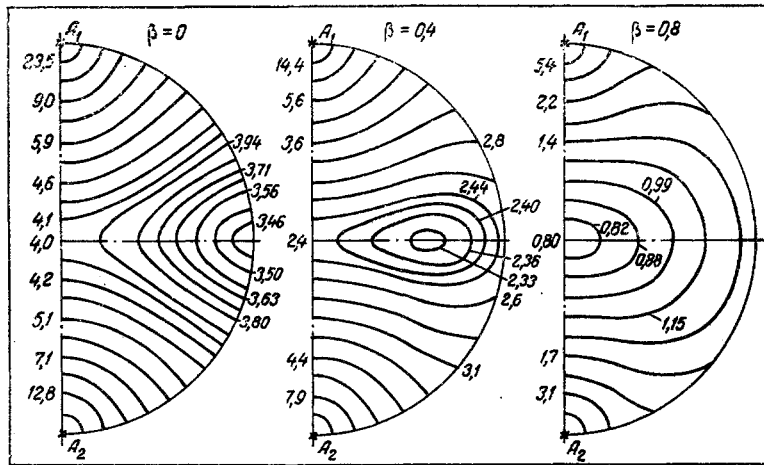

Fig. 2. Homogeneous influx of heat over the surface and heat sources at the poles A_1 and A_2 .

$$\begin{aligned}
 u_{21}(x) = u_{21}(|x|, \vartheta) &= \frac{Q}{8\pi\gamma R^3} |x|^2 \\
 &+ \frac{Q}{4\pi^2\gamma} \int_0^\pi \left[\frac{2}{1 \sqrt{|x|^2 + R^2 - 2|x|R(\sin\vartheta\sin\vartheta_0\cos\varphi + \cos\vartheta\cos\vartheta_0)}} \right. \\
 &+ \frac{1}{R} \ln \left\{ \frac{2R(R + \sqrt{|x|^2 + R^2 - 2|x|R(\sin\vartheta\sin\vartheta_0\cos\varphi + \cos\vartheta\cos\vartheta_0)})}{R + \sqrt{|x|^2 + R^2 - 2|x|R(\sin\vartheta\sin\vartheta_0\cos\varphi + \cos\vartheta\cos\vartheta_0)} - |x|(\sin\vartheta\sin\vartheta_0\cos\varphi + \cos\vartheta\cos\vartheta_0)} \right\} \Big] d\varphi. \quad (17)
 \end{aligned}$$

The integral of the first term in the square brackets is a complete elliptic integral; this is of little convenience, however, since the integral of the second term must be evaluated numerically; thus the evaluation of the first term as an elliptic integral is an unwarranted procedure.

We note a particular case: for $\vartheta_0 = 0$

$$\begin{aligned}
 u_{21}(|x|, \vartheta) &= \frac{Q}{8\pi\gamma R^3} |x|^2 + \frac{Q}{4\pi\gamma} \left[\frac{2}{\sqrt{|x|^2 + R^2 - 2|x|R\cos\vartheta}} \right. \\
 &+ \left. \frac{1}{R} \ln \frac{2R}{R + \sqrt{|x|^2 + R^2 - 2|x|R\cos\vartheta} - |x|\cos\vartheta} \right]; \quad (18)
 \end{aligned}$$

a corresponding expression is obtained for $\vartheta_0 = \pi$ if the sign in front of the terms containing $\cos\vartheta$ is reversed. A second important particular case is obtained for arbitrary ϑ_0 and $\vartheta = 0$ and π , i. e., when the temperature is considered on the axis of symmetry:

$$u_{21}(x_3) = \frac{Q}{8\pi\gamma R^3} x_3^2 + \frac{Q}{4\pi\gamma} \left[\frac{2}{\sqrt{x_3^2 + R^2 - 2x_3R\cos\vartheta_0}} + \frac{1}{R} \ln \frac{2R}{R + \sqrt{x_3^2 + R^2 - 2x_3R\cos\vartheta_0} - x_3\cos\vartheta_0} \right]. \quad (19)$$

Relying on the expressions (17) or (19), we can easily write down, in the form of a repeated integral, the stationary term in the temperature for an arbitrary axially symmetric heat flow.

10. Figure 1 presents the isotherms for a heat influx of total power Q_0 when the flow βQ_0 (β is a parameter) is uniformly (homogeneously) distributed over the surface while the flow $(1-\beta)Q_0$ enters through the north pole A_1 . In this case, by virtue of the relations (16) and (18), we have

$$\begin{aligned}
 u_{21}(|x|, \vartheta) &= \frac{Q_0}{8\pi\gamma R^3} |x|^2 + \frac{(1-\beta)Q_0}{4\pi\gamma} \left[\frac{2}{\sqrt{|x|^2 + R^2 - 2|x|R\cos\vartheta}} \right. \\
 &+ \left. \frac{1}{R} \ln \frac{2R}{R + \sqrt{|x|^2 + R^2 - 2|x|R\cos\vartheta} - |x|\cos\vartheta} \right].
 \end{aligned}$$

To construct the isotherms we expressed this function in the coordinates $\rho = \sqrt{x_1^2 + x_2^2}$, $z = x_3$ and then

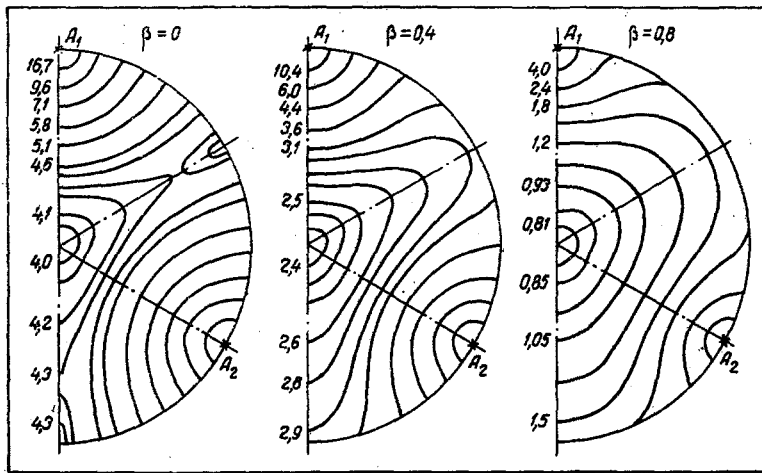

Fig. 3. Homogeneous influx of heat over the surface and heat sources at three points situated on a meridian.

numerically integrated the system of equations

$$\frac{d\rho}{ds} = \frac{1}{|\text{grad } u_{21}|} \cdot \frac{\partial u_{21}}{\partial z}, \quad \frac{dz}{ds} = -\frac{1}{|\text{grad } u_{21}|} \cdot \frac{\partial u_{21}}{\partial \rho}.$$

It is seen that a minimum point for the temperature occurs on the axis of symmetry, which depends on β ; this point can be found from the condition $u_{21} = 0$. An easy calculation shows that the corresponding value of z is the only real root of the equation

$$z(R-z)^2 + (1-\beta)R^3(3R-z) = 0,$$

moreover, $z|_{\beta=0} = -R$, $z|_{\beta=1} = 0$, and z increases with β for $0 \leq \beta \leq 1$. When $\beta < 0$, the minimum of the temperature is reached at the point $z = -R$.

Figure 2 shows the isotherms for the case in which the flow βQ_0 is supplied uniformly through the surface while equal flows $1/2(1-\beta)Q_0$ enter through the north and south poles. Here

$$u_{21}(\rho, z) = \frac{Q_0}{8\pi\gamma R^3} (\rho^2 + z^2) + \frac{(1-\beta)Q_0}{8\pi\gamma} \left[\frac{2}{\rho^2 + (R-z)^2} + \frac{2}{\rho^2 + (R+z)^2} + \frac{1}{R} \ln \frac{4R^2}{[R-z + \sqrt{\rho^2 + (R-z)^2}][R+z + \sqrt{\rho^2 + (R+z)^2}]} \right]. \quad (20)$$

For small β a circle of minimum temperature occurs in the equatorial plane; the radius of this circle satisfies the equation

$$(1-\beta) \left[\frac{2}{(\rho^2 - R^2)^{3/2}} + \frac{1}{R \sqrt{\rho^2 + R^2} (R + \sqrt{\rho^2 + R^2})} \right] = \frac{1}{R^3},$$

from which we deduce that as β is varied from 0 to 0.6 the value of ρ decreases from R to 0. When $0.6 \leq \beta \leq 1$, the minimum temperature is attained at the center of the ball (for $0 \leq \beta < 0.6$ the temperature is a maximum there). When $\beta < 0$, the minimum temperature is attained at the equator.

Figure 3 depicts the case in which the flow βQ_0 is supplied uniformly through the surface while flows $1/3(1-\beta)Q_0$ enter through the points A_1 , A_2 , and A_3 (A_3 and A_2 are positioned symmetrically with respect to the vertical axis). The temperature field here is not axially symmetric. The picture of the isotherms is shown only in the plane passing through the points A_1 , A_2 , and A_3 .

In Fig. 4 we show the case in which the flow βQ_0 is supplied uniformly through the surface while the rest of the flow $(1-\beta)Q_0$ enters uniformly through the equator. Here on the axis of symmetry we have

$$u_{21}(z) = \frac{Q_0}{8\pi\gamma R^3} z^2 + \frac{(1-\beta)Q_0}{4\pi\gamma} \left[\frac{2}{\sqrt{z^2 + R^2}} + \frac{1}{R} \ln \frac{2R}{R + \sqrt{z^2 + R^2}} \right].$$

Exactly the same dependence is obtained as in the dependence of u_{21} on ρ for $z = 0$ in Eq. (20). Therefore,

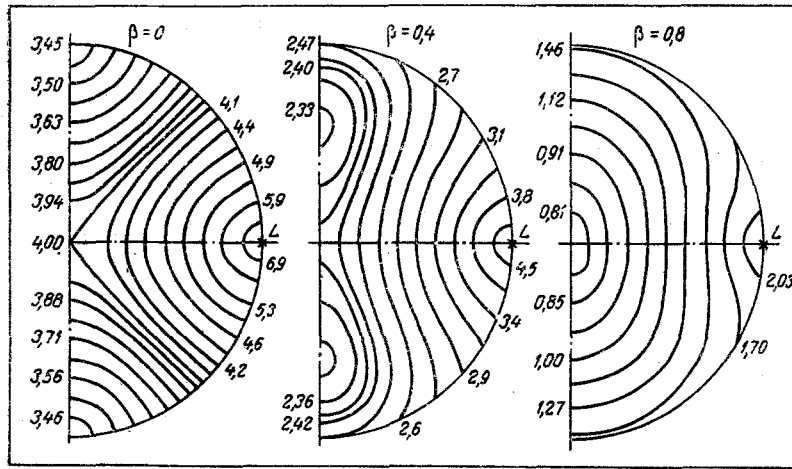

Fig. 4. Influx of heat, uniform over the surface and concentrated uniformly along the equator.

when $0 \leq \beta < 0.6$, the minimum temperature is attained at two symmetrically-placed points on the axis of symmetry whereas, when $0.6 \leq \beta \leq 1$, the temperature is a minimum at the center of the ball (when $\beta < 0$, it is a minimum at the poles). The case $\beta < 0$ corresponds to cooling through the surface and, owing to the nature of the boundary condition, the actual value is smaller.

In the Figs. 1-4 the values shown are those of the dimensionless quantity $\tilde{u}_{21} = 8\pi\gamma R^3 u_{21}/Q_0$.

11. We employ the results obtained above for calculating approximately the thermo-capillary force acting on a small heterogeneous inclusion (for example, a small bubble) W , placed in a liquid filling a container D , under conditions of weightlessness, and initially heated by a constant influx of heat, $q(x)$. We assume that on the boundary Γ of the body W the coefficient of surface tension σ depends linearly on the temperature, $\sigma = \sigma_0 - \sigma_1 u$, and we assume also that the body W introduces no essential perturbations in the temperature field in its vicinity; this latter assumption is certainly satisfied with sufficient approximation. Then the energy of the surface tension associated with Γ is equal to

$$\Pi = \int_{\Gamma} [\sigma_0 - \sigma_1 u(x, t)] dx \approx (\sigma_0 - \sigma_1 \bar{u}^{\Gamma}) |\Gamma|.$$

Therefore, as the thermo-capillary force we can take

$$F = -\text{grad } \Pi \approx \overline{\sigma_1 \text{grad } u^{\Gamma}} |\Gamma| \rightarrow_{t \rightarrow \infty} \sigma_1 |\Gamma| \text{grad } u_{21}(x)$$

(on account of the small size of the body W we omit the averaging sign). Thus, the thermo-capillary force is directed towards the side of the zone of the advancing initial heating.

Suppose that the inclusion W has the shape of a small ball of radius r_0 . Then as this small ball moves with the velocity \mathbf{v} , it is acted on by a viscous force equal, in accord with Stokes' Law, to $-6\pi\eta r_0 \mathbf{v}$, where $\eta = \eta(u)$ is the temperature-dependent viscosity coefficient. Assuming the motion to be quasi-static, we obtain the relation

$$6\pi\eta r_0 \mathbf{v} = \sigma_1 4\pi r_0^2 \text{grad } u_{21}(x), \text{ i.e. } \mathbf{v} = \frac{2\sigma_1 r_0}{3\eta} \text{grad } u_{21}(x).$$

The motion takes place along curves orthogonal to the family of isotherms.

We consider, in particular, the motion of the small ball along the axis of symmetry in the case of axially symmetric initial heating of the ball through its surface. Let the flow entering along S be distributed with the density $b = b(\vartheta)$. Then, by virtue of the relation (19), on the axis of symmetry we shall have

$$u_{21}(z) = \frac{\bar{b}}{2\gamma R} z^2 + \frac{R}{4\pi\gamma} \int_0^{\pi} \left[\frac{2}{\sqrt{z^2 + R^2 - 2zR \cos \vartheta}} + \frac{1}{R} \ln \frac{2R}{R + \sqrt{z^2 + R^2 - 2zR \cos \vartheta} - z \cos \vartheta} \right] \sin \vartheta b(\vartheta) d\vartheta;$$

whence we find the equation of motion of the small ball to be

$$\frac{dz}{dt} = \frac{2\sigma_1 r_0}{3\gamma\eta} \left\{ \frac{b}{R} z - \frac{R}{4\pi} \int_0^\pi \left[\frac{2(z - R \cos \vartheta)}{(z^2 + R^2 - 2zR \cos \vartheta)^{3/2}} + \frac{z - R \cos \vartheta - \cos \vartheta \sqrt{z^2 + R^2 - 2zR \cos \vartheta}}{R(R - z \cos \vartheta + \sqrt{z^2 + R^2 - 2zR \cos \vartheta}) \sqrt{z^2 + R^2 - 2zR \cos \vartheta}} \right] \sin \vartheta b(\vartheta) d\vartheta \right\}.$$

Thus, for the first example of §10 we obtain the equation

$$\frac{dz}{dt} = \frac{\sigma_1 r_0 Q_0}{6\pi\eta\gamma R^3 (R - z)^2} [z(R - z)^2 + (1 - \beta)R^2(3R - z)],$$

from which we can obtain the function $z(t)$, subject to the given initial condition, by numerical integration. In particular, when $\beta = 1$, i. e., when the heat flow enters uniformly through the surface, we obtain, assuming, for simplicity, that all the parameters are temperature-independent,

$$\frac{dz}{dt} = \frac{\sigma_1 r_0 Q_0}{6\pi\eta\gamma R^3} z, \text{ whence } z = z_0 \exp \frac{\sigma_1 r_0 Q_0}{6\pi\eta\gamma R^3} t.$$

The time of exit at the surface S of the ball is given by

$$T = \frac{6\pi\eta\gamma R^3}{\sigma_1 r_0 Q_0} \ln \frac{R}{|x_0|}.$$

LITERATURE CITED

1. H. S. Carslaw and J. C. Jaeger, *Conduction of Heat in Solids*, Clarendon Press, Oxford (1959).
2. A. V. Lykov, *Analytical Heat Diffusion Theory*, Academic, New York (1968).
3. A. G. Temkin, *Inzh.-Fiz. Zh.*, 3, No. 1 (1960).
4. N. S. Koshlyakov, É. B. Gliner, and M. M. Smirnov, *Fundamental Differential Equations of Mathematical Physics [in Russian]*, Fizmatgiz, Moscow (1962).